

## **Owner's Manual Revolution LGR Dehumidifier**

Model F413-230V EU/UK  
LEGEND BRANDS HOLDINGS LTD.

22 Plover Close, Interchange Park, Newport Pagnell, MK16 9PS  
Tel: +44 (0)1908-611-211 Fax: +44 (0)1908-611-363 [www.legendbrandseurope.com](http://www.legendbrandseurope.com)

The Dri-Eaz® Revolution LGR Dehumidifier reduces humidity in enclosed environments by removing water vapor from the air. The Revolution is ideal for water damage restoration, structural drying, construction, and many other applications requiring temporary, high-performance dehumidification.

Patents: <http://www.LBpatents.com>

### ORIGINAL INSTRUCTIONS

#### **WARNING**



**WARNING! Do not alter or modify your dehumidifier in any way. Use only replacement parts authorized by Dri-Eaz Products, Inc. Modifications or use of unapproved parts could create a hazard and will void your warranty. Contact your authorized distributor for assistance.**

**WARNING! Electric shock hazard, rotating fan hazard and hot surface hazards.**

- Inspect the power cord before use. If cord is damaged, do not use. Always grasp the plug (not the cord) to unplug.
- Must be earthed. Insert three-prong plug on power cord into a matching electrically earthed outlet. Do not use adapter. Never cut off third prong. Do not use an extension cord.
- The unit must be operated on a 230V/50 Hz circuit protected by a Residual Current Device (RCD) device.
- Keep motor and wiring dry.
- Always unplug unit before cleaning or servicing.
- Do not attempt to repair the unit. For service, contact your local distributor.

#### **FIRE HAZARD**

- Keep away from open flames and heat sources.
- Do not use or store where vapors from gasoline, solvents, thinners or other flammable materials may be present.

#### **BEFORE YOU BEGIN**

##### **Warranty registration**

Warranty registration procedures vary by country/market. Contact your local distributor for assistance. Registration allows us to better assist you with using, maintaining or servicing your equipment and to contact you in case we have important safety information concerning your Dri-Eaz product. If you determine service is required, have your equipment model, serial number and original proof of purchase available and ask for assistance with obtaining a return material authorization (RMA).

#### **GROUNDING INSTRUCTIONS**

This unit's plug must be inserted into an appropriate outlet that is properly installed and grounded in accordance with all local codes and ordinances.

**WARNING! Improper connection of the equipment-grounding conductor can result in a risk of electric shock. Check with a qualified electrician or service person if you are in doubt as to whether the outlets are properly grounded. Do not modify the plugs provided with the appliance – if the plugs do not fit the outlets, have proper outlets installed by a qualified electrician.**

This equipment is for use on circuits with a nominal rating of no more than 230V.

#### **Handle the unit carefully**

Always operate the unit on a stable, level surface. Do not drop, throw, or place where it could fall. Rough treatment can damage the unit, and may create a hazardous condition or void the warranty.

This unit intended for household and commercial use.

## CONTROLS AND OPERATING INSTRUCTIONS

### Set unit upright

**NOTICE:** Always store, transport, and use the unit in a horizontal position. If the unit is ever placed in a vertical position, return it to the horizontal position and let it stand for at least 30 minutes before turning it on.

### Positioning a Dehumidifier

For best results, operate your dehumidifiers in an enclosed area. Close all doors and windows that open to the outside to maximize water removal efficiency. Place your dehumidifier away from obstructions, and keep it away from anything that could block airflow into and out of the unit. For more information about creating an optimum drying environment, contact your local distributor.

### Set up drain hose

This unit automatically pumps out water on a regular basis. This dehumidifier is equipped with a quick-connect fitting for quick attachment to the provided 12 m drain hose. Unwrap the entire hose and place the open end in a sink, drain, bucket or outdoors – anywhere that water can drain out safely. If you use a bucket or other container for water collection, check it regularly to prevent overflows.

**NOTICE:** Uncoil and straighten the entire drain hose. Do not leave any part of the hose coiled and do not place the end of the hose higher than 4 m above the bottom of the unit. Also check for kinks or other obstructions that might restrict the flow of water. Obstructions may cause a water backup and result in overflows.

### Plug in electrical cord

The unit should be plugged into a 230V/50Hz outlet.

### Startup display and normal display modes

When unit is first plugged in to AC power, the control panel display will briefly cycle through a series of readouts. This is part of the unit's self-diagnosis procedure and no user intervention is required.

### Turn the unit on

The control panel has a display and a touchpad with four keys. Press the  ON/OFF to turn the unit on. The unit will now go through a compressor delay countdown (up to sixty seconds in duration) and a self diagnostics process.

Once the compressor delay countdown and self-diagnostics are complete, the display will switch to **normal display mode**.

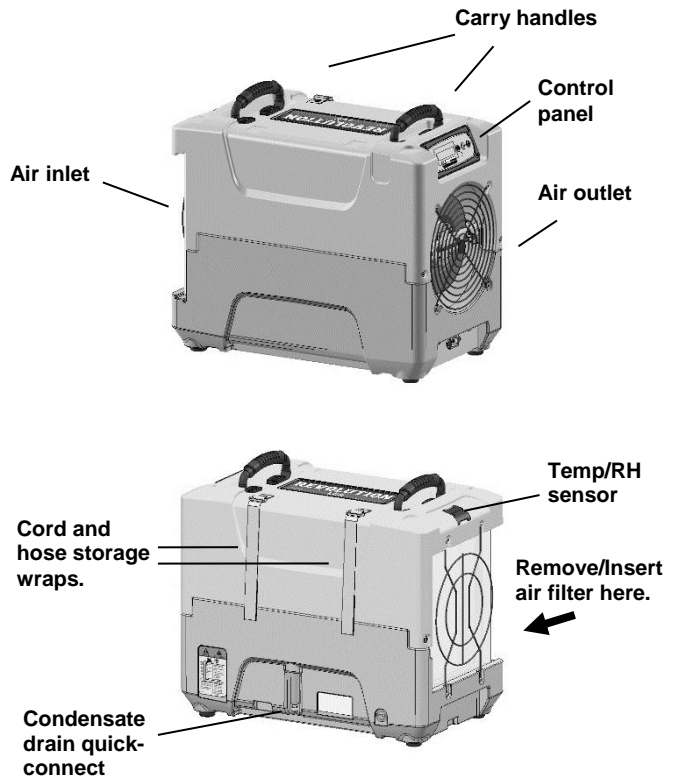

Fig. A: Parts Identification



UNIT ON XXXX HRS  
INLET XXX°C / INLET 00%

The **first line** of the display shows the total number of hours the unit has been in operation. This value may be reset to zero to track job hours (see "Job Hours Reset" below). The **second line** of the display alternates between inlet temperature and inlet humidity.

## User Settings Menu

A number of display settings may be changed by the user. System information can also be displayed. These items are accessed by pressing  DISPLAY MENU. Each press of the key will display the next parameter. When you reach the parameter you wish to adjust, press  MENU SELECTION to increase the value. Press  DISPLAY MENU again to accept the setting and re-start the display cycle.

Note that only menu items followed by a greater-than symbol (>) may be adjusted.

All settings and modes are discussed in detail in Control Panel Guide.

## CONTROL PANEL

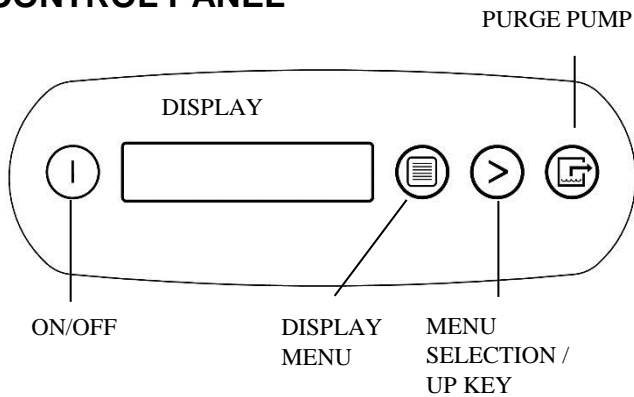

ON/OFF	Press and release to turn unit on or off.
DISPLAY MENU	Press to select next item in menu. Menu item will show in display.
MENU SELECTION / UP KEY	Press to toggle or select values in menu displayed.
PURGE PUMP	Press and release to start purge. Display will count down seconds remaining until purge is complete.

## Error messages

If the onboard diagnostics discover a problem, the unit will display an error message. See "Error Messages," below, for an explanation of each message.

## Control Panel Guide



**ON/OFF.** Press to turn the unit on or off. When the machine is turned on, the display normally reads PLEASE WAIT COMP. DELAY and performs a numeral countdown for a maximum of 60 seconds to 0. This delay allows time for refrigerant pressures to equalize for easier starting. Once the unit completes the compressor delay, the display shows UNIT ON XX HRS and cycles between INLET XX°F and INLET XX%. NOTE: If no compressor delay countdown is displayed, a delay is not necessary and the machine will begin operation immediately.

**DISPLAY MENU.** Press to cycle through the display of additional dehumidifier conditions and User Settings. To return to the main menu, press the ON/OFF key once.

**MENU SELECTION.** Press to change the values of the "User Defined" settings. The MENU SELECTION key acts as the UP key for adjusting the setpoint for Humidistat mode operation. See User Settings Menu (below) for details.

**PURGE.** Press to empty water from the condensate pump reservoir. The display will read PUMP PURGING with a numeral countdown. NOTE: During normal operation, the pump purges automatically.

### Changing settings and viewing system information

Display setting changes and system information can be accessed by pressing  DISPLAY MENU. Each press of the key will display the next parameter (see list below). When you reach the parameter you wish to adjust, press  MENU SELECTION to increase the value. Press  DISPLAY MENU again to accept the setting and re-start the display cycle

Note that only menu items followed by a greater-than symbol (>) may be adjusted.

## USER SETTINGS

Only menu items followed by a greater-than symbol (>) can be adjusted. If no keys are selected for 5 minutes on screens: INLET OUTLET, GRAIN DPR (INLET-OUTLET for 230V models), the display will return to normal display mode. In all the other menu items, the display will return to the normal display mode after 20 seconds. Items without the symbol (>) are for information only and cannot be changed or reset. See “System Messages” below for additional system status messages.

Press **DISPLAY MENU** to proceed to the next menu item. ↓

Press > **MENU SELECTION** to change the setting. →

1. JOB HRS RESET >  
PWR INTERRUPT X

>

1. JOB HR RESET 0  
PWR INTERRUPT 0

Press > to reset to 0.

2. INLET OUTLET  
100' 80% 115' 30%

For information only.

3. GRAIN DPR  
XX GPP

Unit displays GPP if set to Fahrenheit or g/kg if set to Celsius. To change this setting, see menu item 9.

4. FILTER CHECKED  
XXX HRS >

>

4. FILTER CHECKED  
0 HRS

Press > to clear filter hours.

5. COIL CLEANED  
XXX HRS >

>

5. COIL CLEANED  
0 HRS

Press > to clear coil hours.

6. HUMIDISTAT  
MODE OFF >

>

6. HUMIDISTAT  
MODE ON >

Press > to turn ON or OFF. **For maximum dehumidification, make sure HUMIDISTAT is OFF.**

7. HUMIDISTAT  
SETPPOINT XX% >

>

Press > to cycle through 40%–90% at 5% increments (default is 50%).

8. LANGUAGE  
ENGLISH >

>

8. IDIOMA  
ESPANOL >

>

8. SPRACHE  
DEUTSCH >

>

8. LANGUE  
FRANCAIS >

Press > to change language options.

9. TEMP UNITS  
'F >

>

9. TEMP UNITS  
'C >

Press > to change to °F or °C.

10. COIL TEMP  
XX'

For information only.

11. COMP CURRENT  
XX.X A

For information only.

12. FIRMWARE  
3.XX FXXX-XXX

For information only.

13. LIFE HOURS  
XXXX HRS

(Returns to top menu item.)

The following section available only on wireless-equipped units.

14. SENSOR ID  
XXXXXXXXXX

(Returns to top menu item.)

## AT THE END OF THE JOB

To reduce the possibility of drips when moving the unit, follow these additional steps to ensure that all water is removed from the unit.

NOTICE: The unit will complete the defrost cycle even if the unit is turned off **but still plugged in**. If the unit is unplugged during the defrost cycle, excessive water may accumulate in the unit and may drip out when you move the unit.

NOTICE: To ensure the condensate tank empties completely while purging, make sure the unit is placed upright on a horizontal surface.

**1. Do not turn unit off or move it until it has returned to normal operating mode. To confirm unit status, review the control panel. The control panel will display one of the following messages:**

*Defrost in progress:*

---  
**DEFROST XX**

Display mode when unit is in defrost mode. XX indicates the seconds remaining on the defrost cycle.

*Shutdown sequence:*

**WAIT FOR  
DEFROST XX**

Display mode when unit in defrost and unit is powered down (shut off by user). Unit will complete the defrost cycle to remove any built-up ice then purge the pump. XX indicates the seconds remaining on the defrost cycle.

*Drying sequence:*

**WAIT FOR  
UNIT DRYING XXX**

Display mode when unit not in defrost and unit is powered down (shut off by user). Unit will complete the 5 minute drying cycle then purge the pump. XX indicates the seconds remaining on the drying cycle.

*Normal display:*

**UNIT ON XXXX HRS  
INLET XXX°F / XX%**

The unit has completed a defrost and drying cycle and has returned to normal mode. You may now proceed to step 2.

**2. Gently rock the machine to ensure any water remaining on interior surfaces falls into the sump area.**

**3. Press the PURGE key. When the purge cycle is complete, turn the unit off.**

**4. Remove the external drain hose, drain it carefully, coil it and return it to the storage tray on the top of the unit.**

## Fig. B: Disassembly for Cleaning

Remove the 4 screws from the cover and 2 top screws each from the inlet and outlet grills and lift off cover.

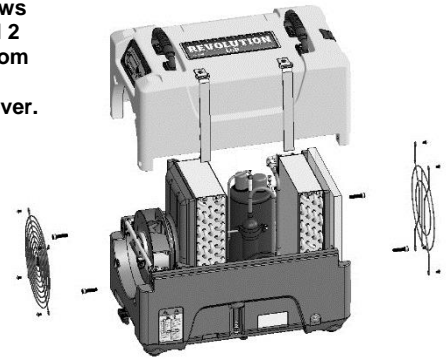

## TRANSPORTATION AND STORAGE

**IMPORTANT:** Before moving, transporting or storing, purge unit and stow hose and power cord as described in the “At the End of the Job” section above.

**NOTICE:** Handle the unit carefully. Do not drop, throw or place the unit where it could fall. Rough treatment can damage the dehumidifier and may create a hazardous condition or void the warranty.

- Do not expose the control panel to moisture, snow or rain.
- Store and transport securely to avoid any damaging impact to internal parts.
- Secure during transport to prevent sliding and possible injury to vehicle occupants.
- Do not transport or store the unit on its front, sides or back. This will help to prevent any remaining moisture from escaping from the unit or flowing into areas outside the sump.

## MAINTENANCE SCHEDULE

**WARNING! ELECTRIC SHOCK HAZARD. Unplug unit before cleaning or servicing.**

**WARNING:** Risk of dust and contaminants exposure. Use of respirator mask and gloves is recommended. If unit has been exposed to potentially dangerous contaminants, clean thoroughly and sanitize before reuse.

**NOTICE:** The unit is fitted with sensitive electronic sensors. Protect the sensors and their lead wires from damage and do not expose them to water or cleaning solution.

**The following tools and supplies are needed to complete the maintenance procedures described in this manual:**

- Philips screwdriver
- 10 mm wrench
- 6 mm hex bit
- ¼ in. nut driver
- Cleaning cloths
- HEPA vacuum cleaner with soft brush nozzle and crevice nozzle.

### Recommended

Cordless drill, small knife, small-jaw pliers, coil cleaning solution, rotomolded housing cleaning solution.

### Before each use

**Inspect the electrical cord for damage.** Look for fraying, cuts, etc. Replace the cord if you find any damage.

**Inspect filter.** Replace if accumulation of dust and debris is visible.

**NOTICE:** Replace used filters only with a new Dri-Eaz filter part no. F583 (24-pack). Other filter types do not provide adequate filtration or airflow.

**IMPORTANT:** Air filters should be replaced whenever the accumulation of dust or debris is visible and after every mold job.

### Monthly

**Inspect coils.** Clean when dust accumulation is visible. In normal use, dust can accumulate and can restrict air-

flow, reducing performance and causing the unit to overheat. Use a vacuum cleaner with a brush tool and a soft cloth to remove any debris. Take care not to damage any interior components.

**To maintain appearance,** wipe interior and exterior surfaces with a damp cloth. For deep cleaning and a lasting, protective shine, use an automotive interior cleaner.

### As Needed

**Clean pump check valve and basin.** If the unit displays the message "ER9 PUMP BLOCKED PUMP & HOSE", the pump check valve and pump basin may need to be cleaned. Remove grills and cover as shown in Fig. B. Remove screws from pump base and lift out pump. Wipe out pump basin with a damp cloth. Unthread barbed fitting with check valve and rinse fitting and check valve with clean water. Reinstall barbed fitting into pump. Do not overtighten. Reinstall pump on base. Reinstall cover and grills. **Clean coils.** With the cover removed, inspect both coils. If excessive dust and debris is present, vacuum thoroughly and/or clean with coil cleaner.

## SYSTEM MESSAGES

The Control Panel will display the following messages based on system performance and environmental conditions. User action, if any is required, is indicated in the third column.

CONTROL PANEL MESSAGE	EXPLANATION	USER ACTION
INITIALIZING	Unit is powering up.	None
FIRMWARE VERSION XXX	Indicates control board firmware version number.	None
FXXX-XXX	Model number.	None
OFF	Unit has finished powering up and is operating.	None
PLEASE WAIT COMP. DELAY XX	60s delay before compressor turns on. Allows system pressure to equalize.	None
UNIT ON XXXX HRS INLET XXX°F / XX%	First line: indicates total operating hours. Second line: Toggles between inlet temperature and inlet RH every 2 seconds.	None
HUMIDISTAT INLET XXX°F / XX%	First line: indicates unit is in humidistat mode Second line: Toggles between inlet temperature and inlet RH every 2 seconds.	None
LOW TEMP INLET XXX°F / XX%	Unit shuts off if inlet temp below 45°F/7°C. Turns back on when inlet reaches 50°F/10°C.	None
--- PUMP PURGING XX	Displays when the Pump Purge button is pressed. Shows time remaining in seconds.	None
HI TEMP CYCLE REMAINING XX MIN	Unit overload limit reached. Cool-down initiated.	None
--- DEFROST XXXX	Unit is defrosting, with countdown in seconds.	None
WAIT FOR DEFROST XXX	Unit turned off when coil is cold or already in a defrost cycle. Proceeds to finish cycle or initiate one to clear the coils of ice before storage.	None
WAIT FOR UNIT DRYING XXX	Occurs when unit is turned off and coil is not frozen. Clears the coils of water before storage.	None
CHECK FILTER > OFF	Prompt to check filter.	Check filter. Press the > key to reset
CLEAN COILS > OFF	Prompt to clean coils and interior.	Clean coils. Press the > key to reset

## ERROR MESSAGES

If the control system detects an error, it will produce an error (“ER”) message. If this occurs, first unplug the unit and then plug it back in. This will usually reset the electronics, and the unit will begin operating normally. If the error message reappears, refer to the explanations and solutions shown below. If these solutions do not fix the problem, contact your local authorized service center.

CONTROL PANEL MESSAGE	EXPLANATION AND SOLUTION
ER4 DEFROST SENSOR CONNECT or ER4 OUTLET SENSOR CONNECT	Temp sensor is open, missing, or shorted. Check that temp sensors are installed correctly on control panel. If error persists, contact service.
ER5 SENSOR CONNECTION ON BD	Inlet Temp/RH sensor is open, missing, or shorted. Check that inlet temp/RH sensor is installed correctly on control panel and inlet shroud. If error persists, contact service.
ER6 CONTACT SERVICE CENTER	Current sensor failure. If error persists, contact service.
ER7 INVALID MODEL SETTING	Incorrect or unsupported DIP switch settings. Contact Dri-Eaz service department for correct DIP switch settings.
ER8 BUTTON STUCK ALL BUTTONS	Key is stuck or has been held down too long. Contact service.
ER9 PUMP BLOCKED PUMP & HOSE	Check for obstructions in drain hose. Check the pump.



## TROUBLESHOOTING

FAULT	CAUSE	SOLUTION
Water drips out when moving unit	Unit was unplugged before purging was complete.	Purge unit before moving. See "At the End of the Job."
Unit does not operate	Unit not switched on. No power to machine.	Switch unit on. Plug in unit; check power cord connection at wall outlet.
Unit operating, but room not dry	Not enough time to dry. Poor air movement in room. Excessive moist air infiltration.	Make sure "Humidistat" is OFF. Allow more time for drying. Increase air movement with air movers. Seal off area to reduce infiltration.
Unit collects too little water	Room air is dry. Room temperature is too low. Filter is clogged. Coils are clogged.	Make sure "Humidistat" is OFF. Confirm humidity level with hygrometer. Increase room temperature. Check filter. Replace as necessary. Check coils. Clean as necessary.
<i>If the problem you are experiencing is not listed here, call your local distributor.</i>		

## SPECIFICATIONS

Name	Revolution LGR Dehumidifier Model F413-230V EU/UK
Dimensions (W x H x D)	31.8 x 45.7 x 54.6 cm
Weight (w/ cord & hose)	28.6 kg
Refrigerant	410A
Amps	3.5 amps at 26.7°C/60% RH
Power	.81kW / 230V / 50Hz
Compressor rating	7050 BTU
Air movement	285 CMH
Water removal	38 L/day 26.7°C/60% RH
Operating temperature range	1–38°C
Sound level	Does not exceed 70 dB
Safety	CE
<i>Specifications are subject to change without notice. Some values may be approximate.</i>	

### PARTS INCLUDED

12 m drain hose with quick-connect fitting.  
7.6 m power cord.  
1 air filter

### FILTER REORDERS

Air filter part no. F583 (24 pack)

### OPTIONAL

Duct Attachment Kit (F530)

**ADDITIONAL PRODUCT INFORMATION** and current documentation is available at  
[www.legendbrandseurope.com](http://www.legendbrandseurope.com)

**FOR PARTS AND SERVICE** contact your local distributor.